

TRAINER
SIŁOWNIE ZEWNĘTRZNE

ZPU ROMEX SP. Z O. O.

UL. HETMAŃSKA 38
85-039 BYDGOSZCZ

@ trainer@trainer.net.pl

607 764 394

52 323 07 12

www.trainer.net.pl

Zestaw nr 6B

Nr katalogowy: 37



DANE TECHNICZNE:

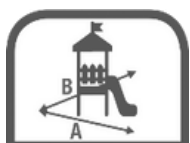

3,90 x 0,80 m



2,10 m



7,40 x 3,80 m



1,20 m

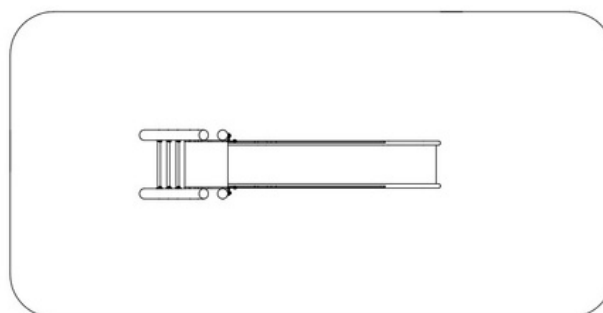

- Nawierzchnie amortyzujące: trawa, piasek, żwir, kora, nawierzchnia syntetyczna (długość nawierzchni sypkich min. 200 mm).
- Urządzenie wykonane zgodnie z normą: PN-EN 1176:1-2:009