



SIŁOWNIE ZEWNĘTRZNE

KARTA TECHNICZNA TWISTER + SŁUP + STEPER

ZPU ROMEX Sp. z o.o.
ul. Hetmańska 38
85-039 Bydgoszcz

tel. 52 323 07 12
tel. kom. 609 521 630
fax 52 322 78 45
trainer@trainer.net.pl

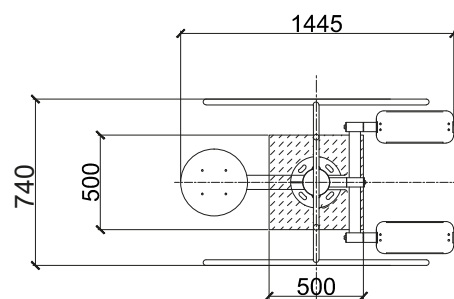
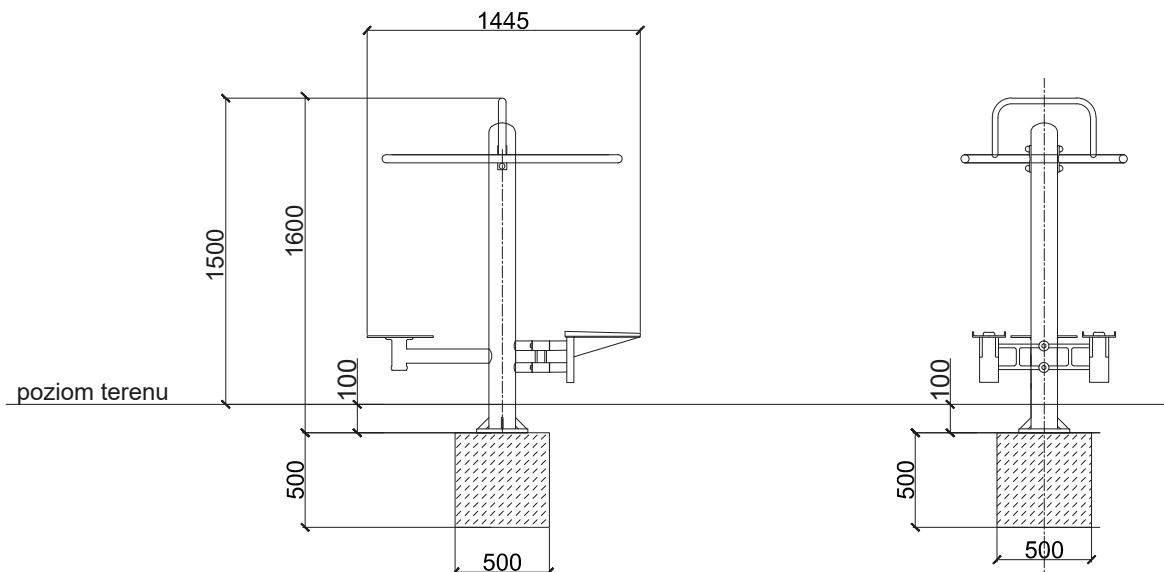

Fundament 100 mm poniżej poziomu gruntu.
Minimalne wymiary fundamentu 500 x 500 x 500 mm.

