



# SIŁOWNIE ZEWNĘTRZNE

## KARTA TECHNICZNA KOŁA TAI CHI DISABLED + PYLON

ZPU ROMEX Sp. z o.o.  
ul. Hetmańska 38  
85-039 Bydgoszcz

tel. 52 323 07 12  
tel. kom. 609 521 630  
fax 52 322 78 45  
trainer@trainer.net.pl

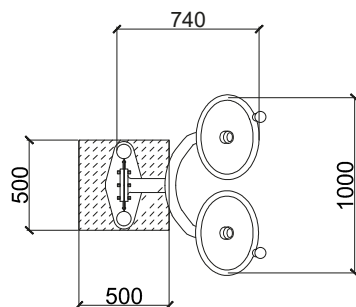
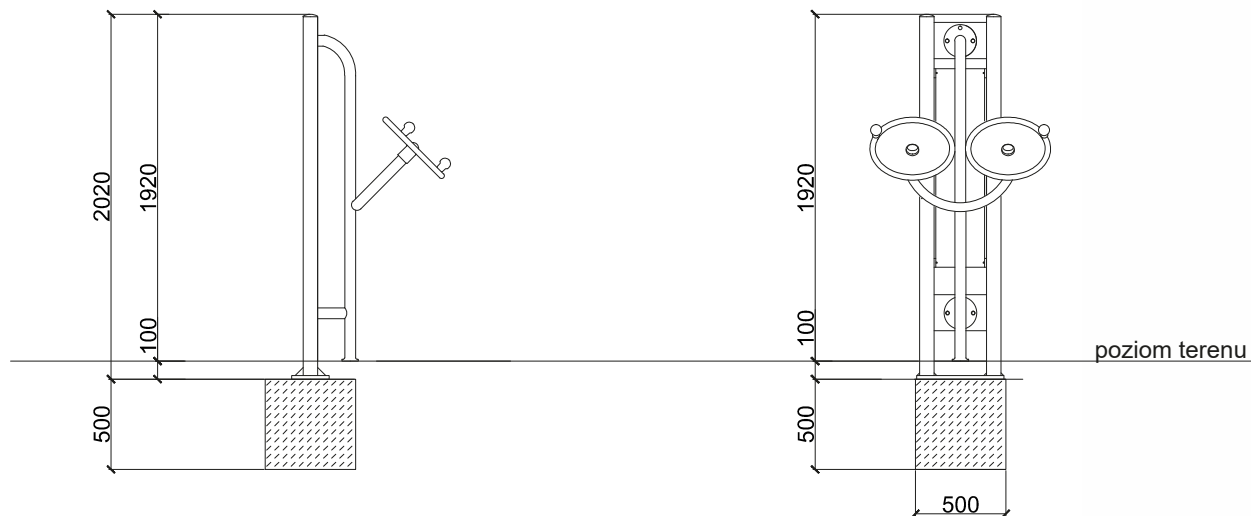

Fundament 100 mm poniżej poziomu gruntu.  
Minimalne wymiary fundamentu 500 x 500 x 500 mm.

